

WM2-M product information sheet

Product Specifications

Fits most: 23" - 42" flat panels

Supports up to: 36.3 kg

Tilt: -5° to +15°

Mounting profile: 49mm

Universal & VESA compliant: 100x100 to 300x400

Mounting: Double-stud

UL listed: Yes

Warranty: 5 years

Color: Black and Platinum

Product Benefits

- Tilt -5° to +15° to reduce glare
- Universal rails for greater panel compatibility
- Lift n' Lock™ allows you to easily attach your flat panel to the mount
- Tension adjustment for variable tilt
- Sliding lateral on-wall adjustment
- Open architecture provides easy access to in-wall wiring
- Locking bar secures panel to mount
- Simple to install and use
- Includes complete hardware kit



Keeping ease of installation in mind, the WM2-M was designed to be installed in a few simple steps

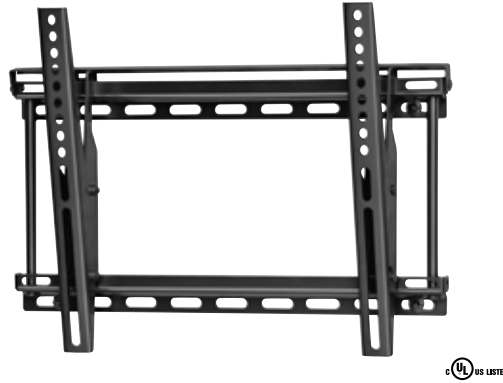

UL LISTED

Series



WM1-S



WM3-S



2006 Custom Retailer EXCITE Award

WM4-M*

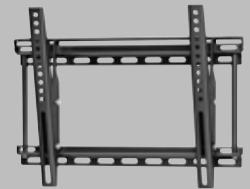

WM2-M**



WM3-PJT

*Also available in small and large

**Available in medium and large, fixed and tilt



OmniMount, an innovator of A/V mounts and furniture for more than a quarter century, is the choice of professional installers and the brand most recommended by flat panel manufacturers. Recognizing the need for an affordable line of mounts, OmniMount offers the WorldMount™ brand of flat panel mounts with maneuverability, adaptability and a stylish look – all at a low cost. The WM2-M is ideal for entry-level consumers looking for an easy-to-use medium tilt mount.



WM2-M technical data sheet



OmniMount, an innovator of A/V mounts and furniture for more than a quarter century, is the choice of professional installers and the brand most recommended by flat panel manufacturers. Recognizing the need for an affordable line of mounts, OmniMount offers the WorldMount™ brand of flat panel mounts with maneuverability, adaptability and a stylish look – all at a low cost. The WM2-M is ideal for entry-level consumers looking for an easy-to-use medium tilt mount.

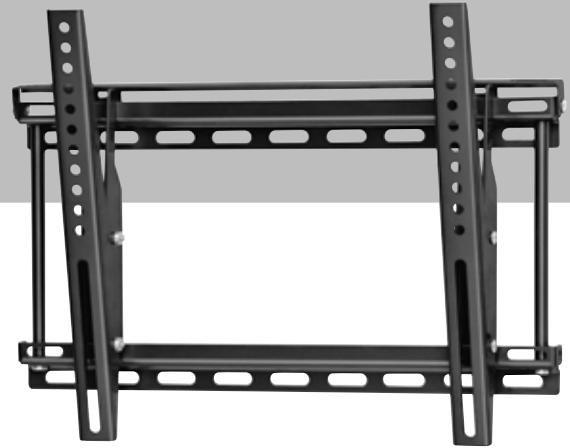

cUL_{US} LISTED

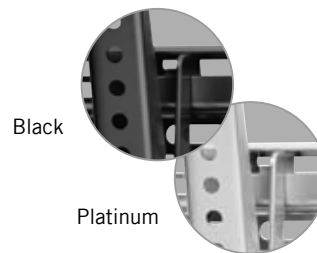

Product Specifications

Fits most: 23" - 42" flat panels

Supports up to: 36.3 kg

Tilt: -5° to +15°

Mounting profile: 49mm

Universal & VESA compliant: 100x100 to 300x400

Mounting: Double-stud

UL listed: Yes

Warranty: 5 years

Color: Black and Platinum

Product Benefits

- Tilt -5° to +15° to reduce glare
- Universal rails for greater panel compatibility
- Lift n' Lock™ allows you to easily attach your flat panel to the mount
- Tension adjustment for variable tilt
- Sliding lateral on-wall adjustment
- Open architecture provides easy access to in-wall wiring
- Locking bar secures panel to mount
- Simple to install and use
- Includes complete hardware kit

	Color	Stock Code	Packaging UPC	MC UPC
Americas	NA	NA	NA	NA
International	Black	1003325-1	728901019401	728901712807
Americas	NA	NA	NA	NA
International	Platinum	1003324-1	728901019364	728901712760

	Dimensions WxDxH (mm)	Wt (kg)
Product Box	238 x 518 x 68	4.7
Master Carton	254 x 533 x 152	9.5

Box Contents	Qty
Wall plate	1
Tilt rail	2
Locking bar	1
Complete mount installation hardware kit	1
Complete panel attachment hardware kit	1
Instruction manual	1
Flat panel compatibility chart	1

WM2-M line drawing

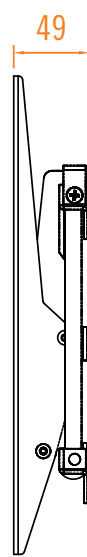
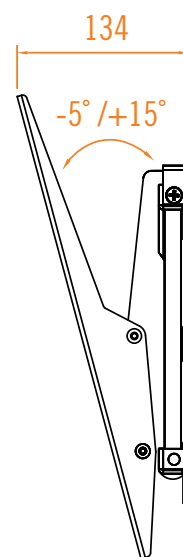
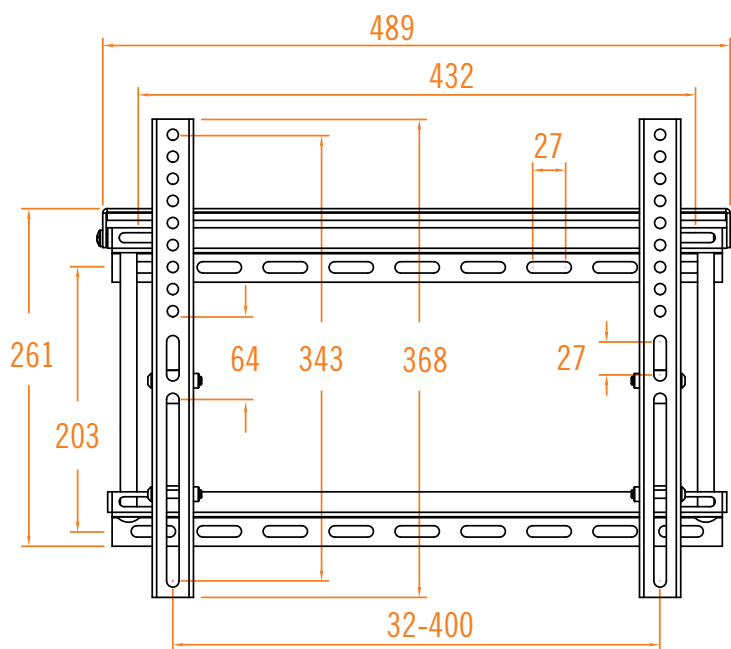

mm